

DINGHY DAVIT & MOTOR LIFT



Kingston Anchors
141 Hickson Avenue
Kingston, Ontario – K7K 2N7
T: 1.613.549.2718 | F: 1.613.547.3879
dave@KingstonAnchors.com



MADE IN CANADA | U.S. STEEL

Material List

<u>QTY.</u>	<u>MATERIAL</u>
2	Boom Arms
2	Boom Pulley Assembly for Boom Arms (50mm Pulley Wheels, 2 1/2" long Fastpin)
2	Double Block Pulley with Hook (32mm Stainless Steel Pulley Wheels)
2	Base Assembly – Mounting Plate, Boom Holder, Bolt, and 4" Long Fastpin
2	Lower Strut Bracket
2	25 ft. length of 5/16" line for lift
2	12 ft. length of 5/16" line for cross supports
4	Strut End Cap (external eye end)
4	3/8" x 1-1/4" Stainless Bolt with Lock Nut
2	3/8" x 3-3/4" Bolt (Used in Base Assembly)
2	20" Support Strut

List of tools and materials required to install Davits system.

1. Drill 3/8" Chuck
2. 5/16" Drill Bit
3. 1/8" Allen Wrench
4. 2 x 9/16" Wrench
5. 8 x 5/16" Stainless steel bolts with large washers and lock nuts for mounting Davits Base Plates (Length to be determined by installer)
6. 8 x 5/16" Stainless steel bolts with large washers and nuts for mounting Strut Brackets to Transom (Length to be determined by installer)
7. Marine Plywood – various to be used as backing plate to reinforce bolt to hull points. Optional stainless steel metal backing plates will offer a stronger mounting surface.
8. Marine Grade Caulking / Sealant
9. Sharp tipped Permanent Marker

MAXIMUM LIFTING WEIGHT IS 350 LBS.

Installation Instructions

Step 1: Plan It

Carefully plan so that when the davits are mounted, they do not interfere with the stern railings, lights or any other previously mounted gear.

Transom Mount or Rail Mount: Plan on using a maximum length **Support Strut**. Locate where you plan on placing the **Lower Strut Bracket**. Measure up from this point 20". If this measurement is still on the transom, you will be a "Transom Mount" set up. If the measurement is above the Transom, you can use either the "Rail Mount" or the "Transom Mount" application. (See picture in step 2) The **Support Struts** can be cut to length. This will be in Step 7.

You will want to lift the dinghy at its transom and bow. A taut chain between two bolts near the bottom of the dinghy transom forms a good lifting point that will not slip from side to side.

The bow can be lifted from the bow fitting. Plan so that when the dinghy is lifted, the **Boom Arms** are in the same vertical plane as the support strut for the base assembly. This is necessary to ensure there are no sideways stresses.



Step 2: Insert Booms

The **Boom Arms** are reversible in that the long side can be used as either the horizontal or the vertical part.

- If you have a reverse transom or swim platform**, then you will want the long arm to be horizontal to keep the dinghy away from the boat.
- If the transom is low**, then you will require the extra height and should use the long arm as the vertical.

Insert the **Boom Pulley Assembly** in the outboard end of the boom and secure with 2" long Fastpin.

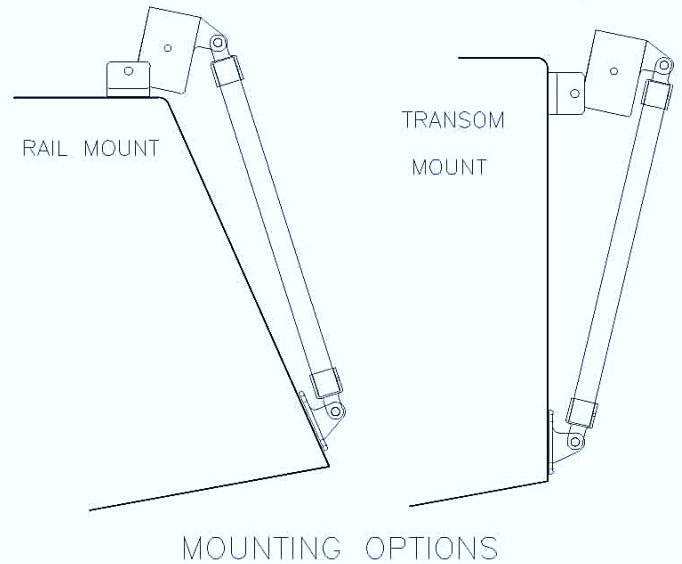
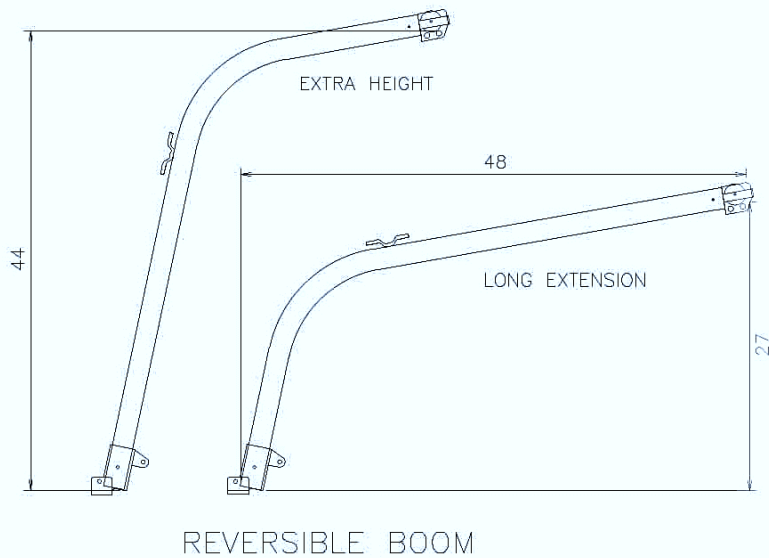

Step 3: Base Assembly to Transom

Once you have decided on the appropriate mounting arrangement to suit your boat, mark the location of holes for drilling. The versatility of the mounting mechanism permits the davits to be mounted a number of different ways, as shown in the picture on page one. It is a good idea at this point, **Before Drilling or Gluing**, to also make sure the mounting bolts will be accessible from the inside and that they will not be in close proximity to wiring or plumbing. The davits may be mounted at any angle you desire but we recommend that the "Horizontal" arm have a slope of 8 to 12 degrees above the horizontal.



Step 4: Backing Plates

Check the proposed location again and install good backing plates to assist in carrying the load. We recommend $\frac{3}{4}$ " marine grade plywood embedded in epoxy resin, or stainless steel plate cut and drilled to match. If you are in doubt, best check with your boat manufacturer.

Step 5: Drill Holes

Place the **Base Assembly** in the desired location, then mark and drill holes for the eight 5/16" bolts. (4 per Base Assembly)
The bolts are not supplied because length of the bolts will vary depending on where and how they are mounted and on which boat.

Use marine grade caulking compound on the base plate and in each hole to ensure a waterproof seal. Insert and tighten the bolts.



Step 6: Locating Lower Strut Bracket Location

Locate the **Lower Strut Brackets** as near to the bottom of the transom as possible for structural support.

As in Step 4, reinforce this area with a backing plate on the inside of the hull to spread the stress load.

These brackets will require eight more 5/16" bolts. The bolts are not supplied because length of the bolts will vary depending on where and how they are mounted and on which boat. **DO NOT** drill holes yet.



Step 7: Cut Strut

In order to get the correct length for the support struts, install a **Strut End Cap** (or External Eye Ends) on one end of the strut using an Allen Key to tighten. (Only Snug, do not over tighten or the set screw may strip) Next attach this end to the **Boom Holder** and connect the **Boom Holder** to the previously mounted **Base Plate**. Carefully measure the required length of the **Support Strut**, making sure it will be long enough to reach the **Lower Strut Bracket** location. Easiest way is to attach a **Strut End Cap** to the **Lower Strut Bracket** and run the **Support Strut** alongside and mark the length.



Step 8: Drill Holes

Before drilling 5/16" holes to mount the Lower Strut Bracket assemble the unit and tighten all bolts. The **Boom Arms** should be angled at 8 – 12 degrees above horizontal. Before drilling the mounting holes, check again to ensure the davits are in the desired position. Mark the holes and drill. Next caulk the **Lower Strut Bracket** and holes and bolt on tightly.



Step 9: Install the Line and Blocks

1. Attach the 25 ft. line to the boom end by passing the line through the outer hole on the **Boom Pulley** and making a knot in the line, double the size of the hole.
2. Next run the line down through the **Double Block Pulley** and then back up through the **Boom Pulley**.
3. Return the line back down to the **Double Block Pulley** and again up through the **Boom Pulley**, and finally back to the cleat to tie off.
4. Next insert the **Boom Arms** into the **Boom Holders** and attach using the supplied **Fastpins**.
5. The two 12 ft. lengths of line are used for attaching from the Boom Pulley to the Dinghy as cross bracing. The purpose is to prevent the dinghy from swinging outside the Boom Arms when your vessel is tacking or leaning to one side. With the dinghy lifted into the Davits, attach the line to the open hole in the Boom Pulley as you did with the 25 ft. line. Next, cross the two 12 ft. lines, one to the bow of the dinghy and the other to the stern of the dinghy.



Your new davits should now be ready for a shakedown. Happy boating.

Motor Lift

Motor Lift fittings are available from Kingston Anchors. These attach to the Stern Railing of your boat and you use one of the Boom Arms to easily lift the outboard motor for the dinghy, on and off your boat.

Maximum lifting capability of one boom arm using the Motor Lift fittings is 100 lbs.

